



OCEANREEF®  
underwater, naturally.



For nearly 70 years, OCEAN REEF has been involved in the underwater diving industry. We have contributed much to this industry, from fins and snorkels to the most modern systems of underwater communication. Through the spirit of intrepid pioneers, brilliant inventors, passionate divers, and dynamic entrepreneurs, OCEAN REEF has been able to turn dreams into reality in the underwater world.



OCEAN REEF USA



MESTEL Safety ITALY

In order to limit our paper consumption, and as a part of our environmental friendly and responsible approach, OCEAN REEF prefers to put user documentation online rather than print them out.

Please refer to our web site:  
[diving.oceanreefgroup.com/support/](https://diving.oceanreefgroup.com/support/)

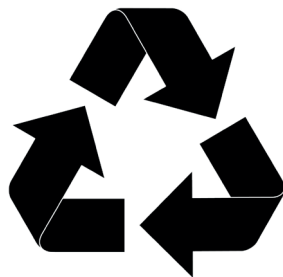

© OCEAN REEF 2020

# EXTENDER INSTRUCTION MANUAL





## TABLE OF CONTENTS



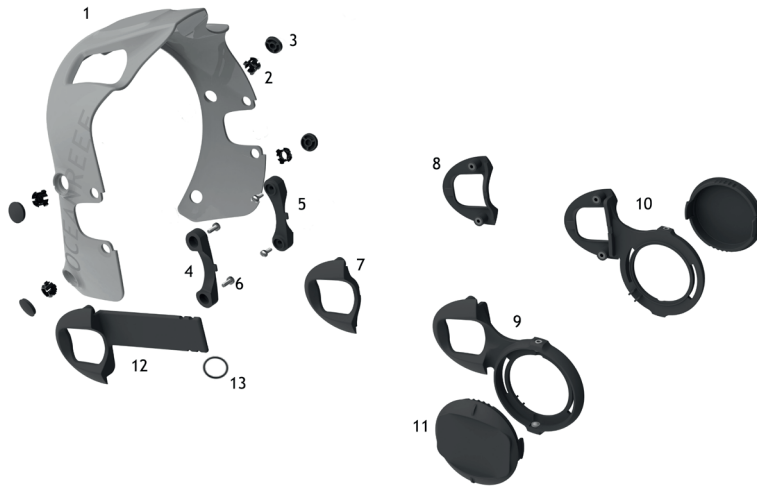





PART LIST	5
EXTENDER PRODUCT OPTIONS	7
(SPACE EXTENDER) - IN THE BOX	8
ASSEMBLY	9
COMMUNICATION SUPPORT	13
ACCESSORIES	15
EXTENDER FRAMES AVAILABLE COLOURS	22
CAUTIONS AND WARNINGS	23
WARRANTY	24
CODES	25



## PART LIST



Number	Name	Quantity	Picture
1	Frame	1	
2	Bushing	4	
3	Bushing Cover	4	
4	L Bridge	1	
5	R Bridge	1	

6	M3 screw	4	
7	L Neutral	1	
8	R Neutral	1	
9	L Earphone support	1	
10	R earphone support	1	
11	Earphone plug	2	
12	Comm support (New NACS)	1	
13	<u>Oring 117</u>	1	

Extender frame, kit and accessories are compatible with all Gdivers IDMs, Neptune Space 2006 IDMs onward, Raptor IDMs.

## Extender Product Options

### (EXTENDER FRAME) - In the box

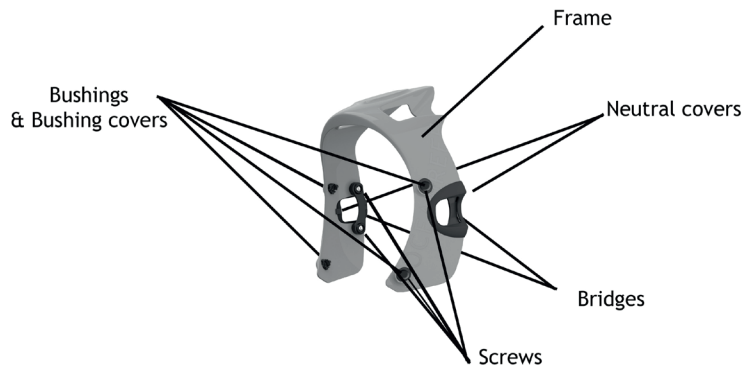

### (EXTENDER KIT) - In the box

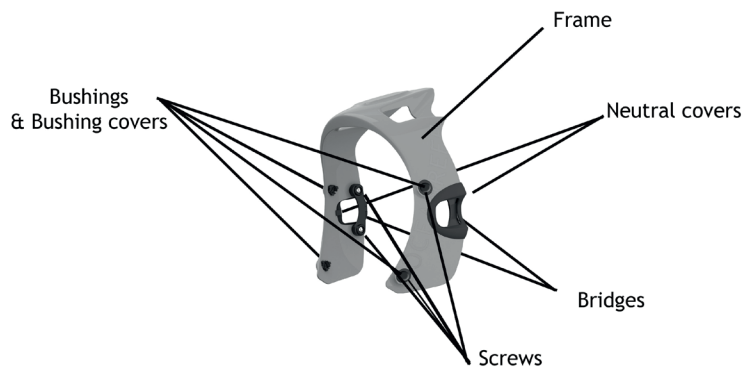

earphone supports



earphone plugs



comm support (new NACS)



oring 117

(SPACE EXTENDER) - In the box



IDM + Extender  
frame, assembled



earphone supports



earphone plugs



comm support (new NACS)



oring 117

ASSEMBLY

STEP 1.



Parts 1 + 4 + 5 + 6 + 7 + 8

#UNDERWATERNATURALLY



Look for  
L and R indications on  
Parts 7 and 8.

Small flap inside of the  
Frame.

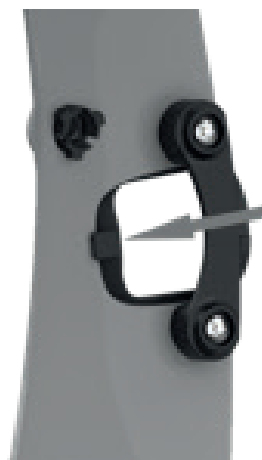

## STEP 2.

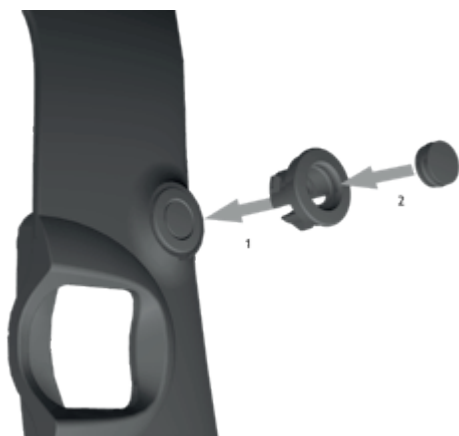

**CLICK!**

Parts 2+3



*CLICK Extender Frame Assembled*

**STEP 3.**



4x Straps must pass inside the frame, through the holes.



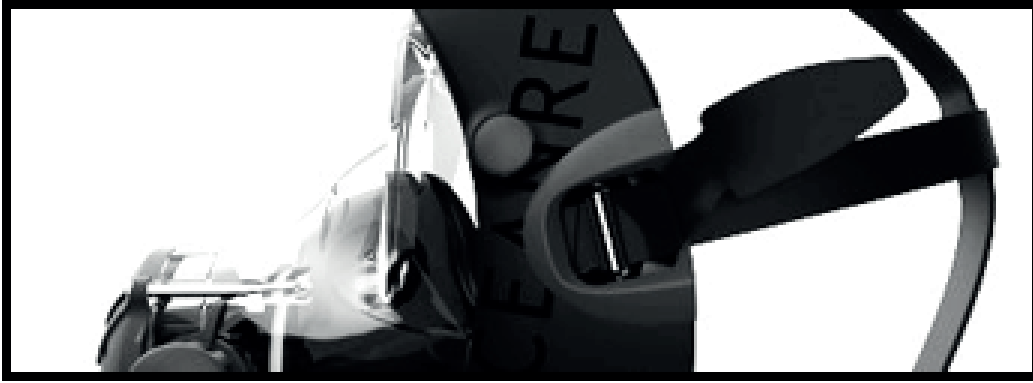

*DM with assembled frame (straps detail).*

## STEP 4.



**CLICK!**

4x

Assemble frame on mask.





## EXTENDER KIT & SPACE EXTENDER Communication Support

Assembling the new NACS system (communication device support). Compatible with all GSM models (comm units not included).

### STEP 1.



*Parts 1+12+4+6.*

## STEP 2.



Part 13



*IDM + new NACS + comm unit.*

## ACCESSORIES

*Assembling multipurpose rotating support + new MHA-2. Multipurpose support can mount accessories and MHA-2, simultaneously.*

### STEP 1.



*Parts 1+4+5+6+9+10.*

## STEP 2.

Add GSM GPower SL comm unit (not included); Add new MHA-2 earphones (not included) or MHA-2 earphones as with new GSM GPower SL.



Secure ear-Phones  
with Orings



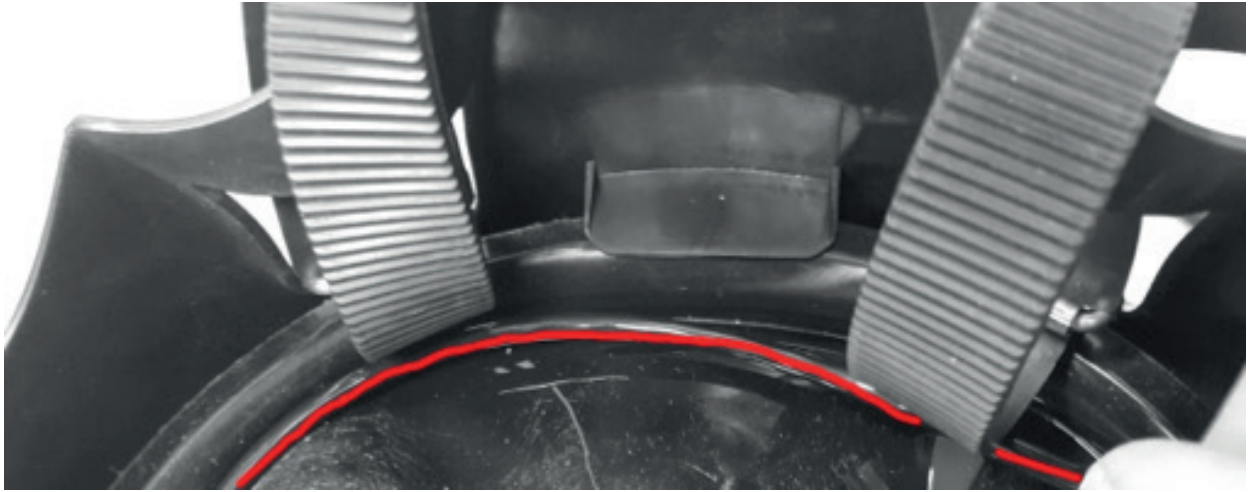

#UNDERWATERNATURALLY



*Place wire under straps and above face seal following contour.*





*Hold cable in place with 3d Oring - as shown.*







#UNDERWATERNATURALLY



*Extender IDM + MHA-2.*



## STEP 3.

Assembling earphone plug (multi purpose surface)

  
**CLICK!**



  
*Rotates 30°*  
*Click,click,click*



#UNDERWATERNATURALLY

Extender Frames Available colours.



Accessories can be mixed mounted as shown.



2 slight position holes signal where part number 12 can be drilled to create personalized mounts for accessories



## Cautions and warnings

- Do not use solvents (such as diluents) to clean the product. They can cause irreparable damage. Only use neutral detergents.
- Rinse the product thoroughly after each use with fresh water.
- Store in a cool, dry place.
- Don't expose to extreme low or high temperatures.



The frame does not serve as a helmet and is not intended to prevent injuries.



The warranty and OCEAN REEF do not cover or approve directly of any modification or alteration occurred to the products by the customer.

## Warranty

- OCEAN REEF communication units are guaranteed to be free of material or manufacturing defects for a period of 24 months from the time the unit is purchased. For the duration of the guarantee, the Company's responsibility is limited to replacement of any parts that are defective in our opinion, and that have not been used incorrectly or handled negligently. The unit must be returned to the outlet from which it was bought, along with the warranty card.
- Even during the guarantee period, this guarantee shall not be valid where:
  1. Damage was caused by incorrect handling or carelessness.
  2. Damage was caused by the unit falling after it was purchased.
  3. Damage caused by fire, earthquake, floods, lightning, or other natural disasters, pollution or electrical charges.
  4. The warranty card is lost or not found.



## Extender Kit product line codes

<i>COLOR</i>	<i>SKU</i>	<i>UPC</i>
BLACK	OR025040	764500001447
WHITE	OR025044	764500001485
GREEN	OR025043	764500001478
YELLOW	OR025043	764500001454
ORANGE	OR025041	764500001461
COBALT	OR025038	764500011422
EMERALD	OR025039	764500011439

## Space Extender product codes

<i>COLOR</i>	<i>SIZE</i>	<i>SKU</i>	<i>UPC</i>
ALL BLACK	S/M M/L	OR025102 OR025103	764500001386 764500001393
ALL YELLOW	M/L	OR025107	764500001423
ALL ORANGE	M/L	OR025108	764500001430
ALL COBALT	S/M M/L	OR025109 OR025110	764500011514 764500011521
EXTENDER 100	M/L	OR025101	764500001379

**NOTE:**

-----

-----

-----

-----

-----

-----

-----

-----

-----

-----

-----

-----

-----

-----

-----

-----

-----

-----

-----

-----

-----

-----



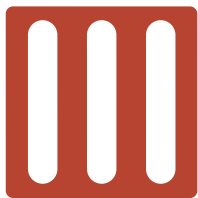

Ocean Reef Group



**MESTEL Safety s.r.l**  
Via Arvigo 2, 16010 Genova (Italia)  
Phone +39 010 7082011  
E-mail: [infoitaly@oceanreefgroup.com](mailto:infoitaly@oceanreefgroup.com)

**OCEAN REEF Inc**  
2510 Island View Way  
Vista, CA 92081  
Phone +1 760 744 9430  
Fax +1 760 744 9525  
E-mail: [operator@oceanreefgroup.com](mailto:operator@oceanreefgroup.com)



[diving.oceanreefgroup.com](http://diving.oceanreefgroup.com)  
[oceanreefgroup.com](http://oceanreefgroup.com)

