

SL35TX First Stage
OWNER'S MANUAL



OCEAN REEF®
underwater, naturally.

For nearly 60 years, OCEAN REEF has been involved in the underwater diving industry. We have contributed much to this industry, from fins and snorkels to the most modern systems of underwater communication. Through the spirit of intrepid pioneers, brilliant inventors, passionate divers, and dynamic entrepreneurs, OCEAN REEF has been able to turn dreams into reality in the underwater world.



OCEAN REEF USA



MESTEL Safety ITALY

In order to limit our paper consumption, and as a part of our environmental friendly and responsible approach, OCEAN REEF prefers to put user documentation online rather than print them out.

Please refer to our web site:
www.oceanreefgroup.com



© OCEAN REEF 2016

SL35TX First Stage OWNER'S MANUAL

TABLE OF CONTENTS

INTRODUCTION	4
WARNING, CAUTION, NOTES	4
DESCRIPTION	5
GENERAL PRECAUTIONS AND WARNINGS	6
AFTER DIVING	7
SERIAL NUMBER	7
MAINTENANCE AND CLEANING/STORAGE	8
Schematic and parts list	9
Warranty	11

The DPIs (Individual Protective Device) scrutinized in these operating instructions have undergone every possible test for design validation by:

Germanisher Lloyd
Vorsetzen 35
20459 Hamburg—Germany
Notified Body n.: 0098

Full face Mask Neptune Space and First Stage SL35TX

comply with CE Certification in accordance with 89/689/EEC directives under the UNI EN250:2000 standard rules for underwater activities , including cold water use.

PREMISE

The DPIs in question are a separate part of the self-contained underwater breathing apparatus, commonly known as SCUBA.

They comply to European regulation EN-250:2000. They can be stored at a temperature of between 32° and 140° F. It is necessary that this equipment only be used by fully trained, certified divers.

Operating restrictions: The DPIs in question can be used only with OCEANREEF Neptune SPACE masks and the air supply must meet the requirements of EN 12021. Incorrect use, non-original spare parts and insufficient or poor maintenance, besides being dangerous to the health and life of the user, releases **MESTEL Safety** of any responsibility and nullifies the warranty.

The series of DPIs described in the following manual are the following:

First Stage SL35TX (YOKE:9922 - DIN:9923)

WARNINGS, CAUTIONS, NOTES

Pay special attention to information provided in warnings, cautions, and notes, that is accompanied by these symbols:



A **WARNING** indicates a procedure or situation that, if not avoided, could result in serious injury or death to the user.



A **CAUTION** indicates any situation or technique that could cause damage to the product, and could subsequently result in injury to the user.

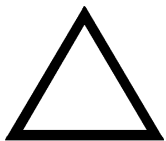

A **NOTE** is used to emphasize important points, tips, and reminders.

SL35TX First stage

DESCRIPTION



- The Space Masks are CE certified with this, high performance and balanced diaphragm first stage with anti-freeze kit.
- Adjustable intermediate pressure.
- Made of chrome plated brass, with a stainless steel piston and spring, and a Teflon seat.
- Standard yoke connection 232 bar (3364 Psi).or DIN 300bar (4351 PSI)
- 2 high-pressure ports.
- 4 low-pressure ports.
- Flow rate of approx. 4800 l/m at 140 bar.



The high quality of the product does not allow the user to ignore the problems connected with the correct use of the product and the rules for safe diving.

GENERAL PRECAUTIONS AND WARNINGS



Before using this gear, you must have successfully received training and certification in the technique of SCUBA diving from a recognized certification agency (or any U.S. Military or government operated diving school). Use of this equipment by a person who is not certified by a recognized agency shall render all warranties, express or implied, null and void.



Use of SCUBA equipment by uncertified or untrained persons is dangerous and can result in serious injury or death.



Always pressurize your SCUBA gradually by opening the cylinder valve SLOWLY.



NEVER lubricate any part of the SL35TX or cylinder valve with any lubricant. Lubrication must only be performed by an OCEAN REEF trained technician.



DO NOT leave a cylinder standing unsecured with the SCUBA attached to the valve. Doing so may cause permanent damage to the Neptune Space and cylinder valve if the cylinder falls over against the first stage.



Factory prescribed service for this product must be performed at least once annually by a factory trained OCEAN REEF Service Technician who is employed by an Authorized OCEAN REEF Dealer. Repair, service, disassembly, or first stage adjustment must not be attempted by persons who are not factory trained and authorized by OCEAN REEF.

Neptune Space and SL35TX are not CE certified to be used with NITROX!



When diving in cold water (below 45⁰ F, or 7⁰ C), you must have received training and certification in the techniques of cold water diving from a recognized training agency.

Before connecting the regulator to the tank, check the following:

- Check that the O-ring on the tank is in place on the valve and is in perfect working condition (INT WITH Yoke nipple CGA 850 version only). If it is damaged or missing, it should be replaced.
- Verify that the instrumentation and accessories have been installed correctly.

AFTER DIVING



1. Make sure the dust cover is firmly in place to keep water out of the first stage.
2. Carefully rinse the regulator with fresh water.
3. When storing equipment, do not tightly loop the hoses and avoid pulling on them when the regulator is attached to the tank.



OCEAN REEF *highly recommends that you practice in a pool before using your SCUBA in open water.*

SERIAL NUMBER

The SL35TX is marked with a serial number that identifies the product for warranty purposes.



MAINTENANCE AND CLEANING

TYPE OF ACTION	BEFORE A DIVE	AFTER A DIVE	EVERY YEAR	EVERY 2 YEARS
RINSE		X		
GENERAL FUNCTION CHECK	X			
REGULATOR SERVICING			X	

STORAGE

The SL35TX must be stored in a dry place with no direct sunlight and far from sources of heat. Do not store it at temperatures below -4°F (-20°C) or above +122°F (+50°C)

For more information watch the tutorial videos on www.oceanreefgroup.com

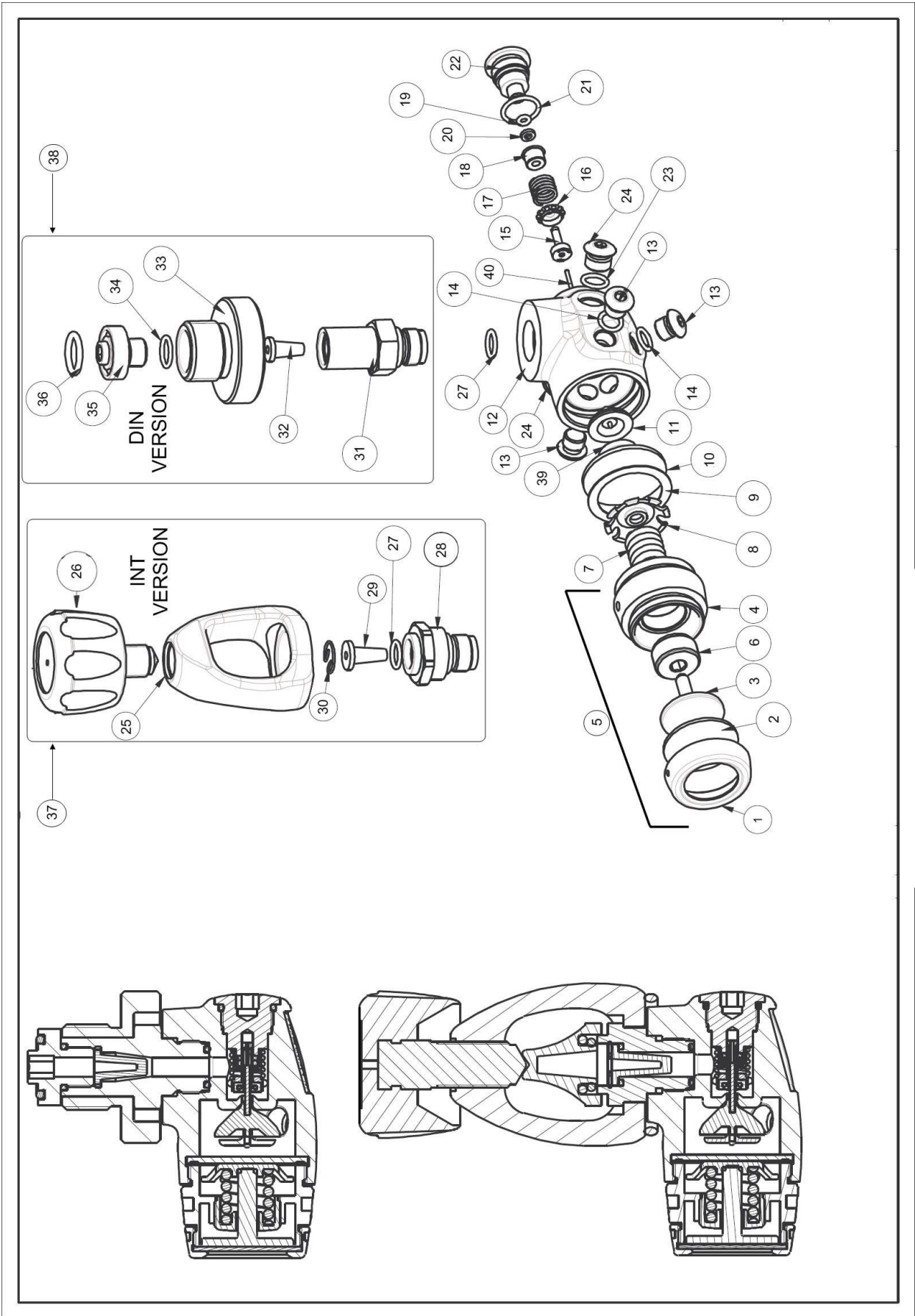

SL35TX First Stage

Key	OR Code	DIN	YOKE	Designation
1	9810	1	1	Retaining cap
2	9811	1	1	Diaphragm Ø33 x 1.5
3	9812	1	1	Pressure piston
4	9813	1	1	Intermediate ring
5	9814	1	1	Anti freeze kit
6	9815	1	1	Adjusting screw
7	9816	1	1	Spring
8	9817	1	1	Spring Plate
9	9818	1	1	Friction Ring
10	9819	1	1	Diaphragm Ø36.9 x 2
39	9849	1	1	Piston guide plate
11	9820	1	1	Piston guide
40	9850	1	1	Guide
12	9821	1	1	Regulator body
13	9822	3	3	LP plug, 3/8 UNF
14	9823	4	4	O-ring 2031 (7,65 x 1,78)
15	9824	1	1	Piston
16	9825	1	1	Guide ring
17	9826	1	1	Spring
18	9827	1	1	Retaining cap
19	9620	1	1	O-ring 2012 (2,9 x 1,78)
20	9829	1	1	Back pressure ring 3,2 x1,5
21	9411	1	1	O-ring 2056 (14,00 x 1,78)
22	9831	1	1	Balancing chamber
23	9832	2	2	O-ring 108 (8,73 x 1,78)
24	9833	2	2	HP plug, 7/16 UNF
25	9834		1	Yoke INT, 9/16-18 UNF
26	9835		1	Yoke screw, 9/16-18 UNF
27	7831	1	2	O-ring 2037 (9,25 x 1,78)
28	9837		1	Yoke fastener
29	9838		1	Filter element YOKE
30	9839		1	Retaining ring
31	9840	1		Hand wheel fastener, 300 bar
32	9841	1		Filter element DIN
33	9842	1		Hand wheel DIN, 300 bar
34	9843	1		O-ring 10,82 x 1,78
35	9844	1		Retaining screw DIN, 300 bar
36	9845	1		O-ring 11,00 x 2,5
37	9846			Conversion kit, YOKE
38	9847			Conversion kit DIN, 300 bar
	OR003801			Dust Cap
	OR009924			Annual maintenance kit SL35TX INT
	OR009925			Annual maintenance kit SL35TX DIN

WARRANTY

1. OCEAN REEF SL35TX is guaranteed to be free of material or manufacturing defects for a period of 24 months from the time the unit is purchased.
2. . For the duration of the guarantee, the Company's responsibility is limited to replacement of any parts that are defective in our opinion, and that have not been used incorrectly or handled negligently. The First Stage must be returned to the outlet from which it was bought, along with the warranty card.
3. Even during the guarantee period, this guarantee shall not be valid where:
 - Damage was caused by incorrect handling or carelessness.
 - Damage was caused by the first stage falling after it was purchased.
 - Damage caused by fire, earthquake, floods, lightning, or other natural disasters.
 - The warranty card is not produced.
 - Our name, the date of purchase, and the seller's name do not appear on the warranty card.

MESTEL Safety s.r.l
Via Arvigo 2, 16010 Genova (Italia)
Phone +39 010 7082011
E-mail: ocean.reef@oceanreefgroup.com

OCEAN REEF, Inc.
1699 La Costa Meadows Dr. Suite 101 San Marcos, CA 92078
Phone +1 760 744 9430 Fax +1 760 744 9525
E-mail: operator@oceanreefgroup.com

OCEAN REEF on the Web:
www.oceanreefgroup.com

© OCEAN REEF 2016